

## Triple Projection System (TPS)

Engineered and built for maximum performance in a command and control environment, this system offers proprietary features not available on any other multiple projection system. Vellicom Tactical's TPS supports three 60" diagonal images, or up to 12 with the additional electronics package. Generous inputs/outputs for HDMI, VGA, USB and numerous content sources.



**Case Dimensions:**  
65" L x 28" D x 32" H

**Deployed (excluding table):**  
164" L X 28" D X 73" H

**Weight:** 280 lbs.



### KEY FEATURES AND BENEFITS:

- Aircraft-quality engineering including cam locks, snap handles and projector yokes for dependable, accurate and trouble-free setup and performance.
- Three high-lumen, state-of-the-art ultra short throw LED/laser projectors, featuring cool run technology and no lamp replacement, store securely in poly cases to handle challenging field conditions.
- Extra tough smooth-glide tracks instantly locate and lock each projector into position.
- System includes three 35' high speed, slim and flexible fiber optic HDMI cables.
- The custom 13 ft. high definition professional vinyl screen attaches easily onto Vellicom Tactical's proprietary Z-Fold Rigid Aluminum Frame™.
- Mildew resistant screen is easily cleaned with mild soap and water.
- Durable mobile aluminum case with Lock wheels; cover conveniently converts to a heavy-duty control table.

**SETS UP  
AND  
TEARS  
DOWN IN  
MINUTES!**

**more >>**



### Control Panels and Indicators:

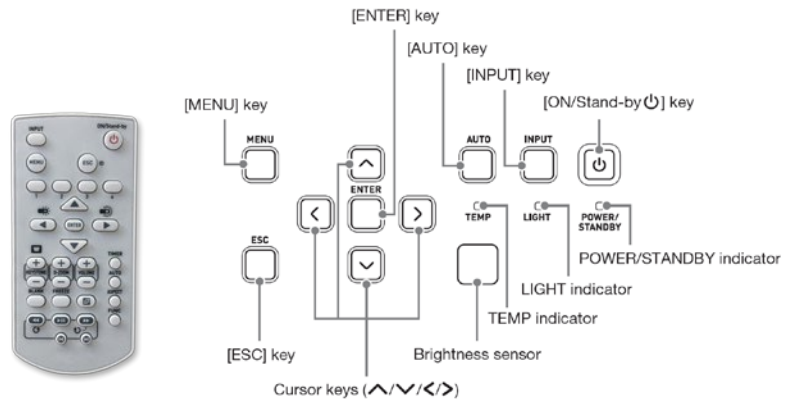

### Projector Features:

- 3500 Lumens (vivid even in sunlight)
- Ultra Short-Throw Projection (60" image from just 5")
- Dust Resistant Design keeps images bright and dust-free with no filter required
- Built-in 16W Speaker
- Quick On (5 seconds to full brightness)
- Instant Off (No cooling down required)

### Ports and Terminals:

- LAN terminal
- USB-A
- Logo port
- HDMI 2 terminal
- HDMI 1 terminal
- Audio In 1 terminal
- Audio In 2 terminal
- Monitor Out terminal
- Computer In 1 terminal
- Computer In 2 terminal
- Microphone terminal
- Audio Out terminal
- Audio In R/L terminal
- Video terminal
- S-Video terminal
- Serial port



### Case cover converts to heavy-duty control table

Built-in legs in the lightweight aluminum case cover provides a sturdy control table for your laptops and staff use.



Commercial-grade screen will handle high definition images up to 16K, is easy to keep clean and resistant to fold creases

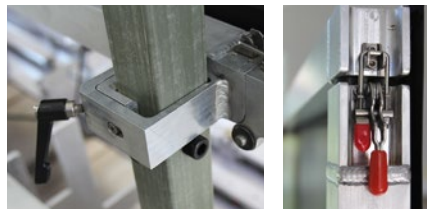

### Advanced Engineering and Integration

The Vellicom Tactical Triple Projection System™ is engineered and integrated with aircraft-grade hardware to ensure reliable and quick setup in the most challenging of field conditions.

Up to four devices can connect to each projector, including two HDMI ports for three simultaneous computer sources.

Custom engineered projector track and mounting systems ensure stable operation and easy tweaking of focus and all other projection settings.

